















































































































































**HONDA GX390K1QA2/GX390U1QA2 — AIR CLEANER ASSY.**

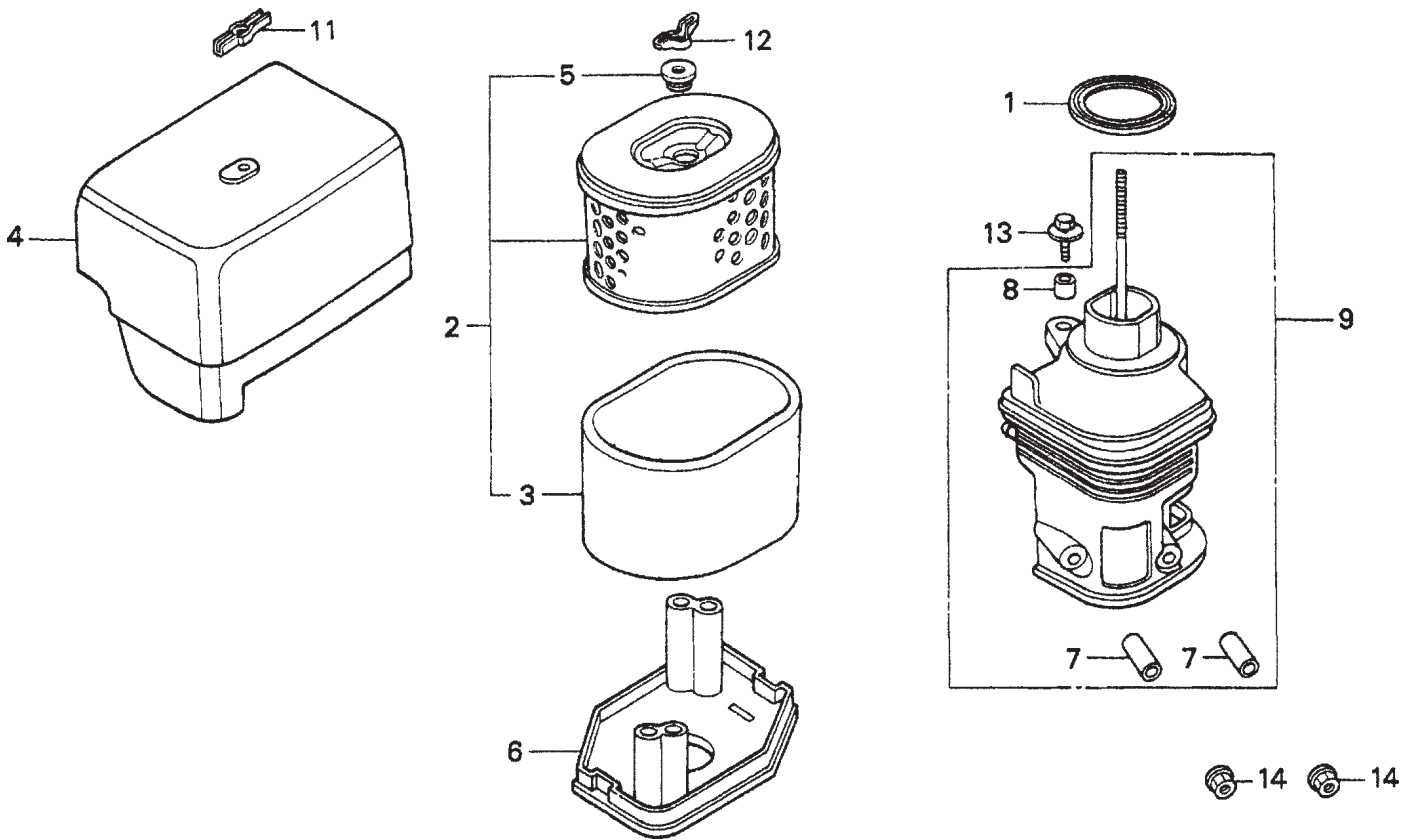

**HONDA GX390K1QA2/GX390U1QA2 — AIR CLEANER ASSY.**

<u>NO.</u>	<u>PART NO.</u>	<u>PART NAME</u>	<u>QTY.</u>	<u>REMARKS</u>
1	16271ZE2000	GASKET, ELBOW	1	
2	17210ZE3010	ELEMENT, AIR CLEANER .....	1	INCLUDES ITEMS W/#
3#	17218ZE3000	FILTER, OUTER	1	
4	17231ZE3W01	COVER, AIR CLEANER	1	
5#	17232891000	GROMMET, AIR CLEANER	1	
64	17235ZH9N00	NOSE, SILENCER	1	
6◇	17235ZH9N00	NOSE, SILENCER .....	1	S/N 1040439 AND BELOW
6◇	17235ZH9N01	NOSE, SILENCER .....	1	S/N 1040440 AND ABOVE
7*	17238ZE2310	COLLAR, AIR CLEANER	2	
8*	17239ZE1000	COLLAR B, AIR CLEANER	1	
9	17410ZH9N00	ELBOW, AIR CLEANER .....	1	INCLUDES ITEMS W/*
11	90203ZA0800	WINGNUT, 6MM	1	
12	90325044000	WINGNUT, TOOL BOX SETTING	1	
13	90009ZE2003	BOLT- WASHER 6X22	1	
14	9405006000	NUT, FLANGE 6MM	2	



MAQUINARIA PARA CONSTRUCCIÓN S.A. DE C.V.



- 4 GX390K1QA2: Model EM120 December 2006 And Below
- ◇ GX340U1QA2: Model EM120 January 2007 And Above

**HONDA GX390K1QA2/GX390U1QA2 — CAMSHAFT ASSY.**

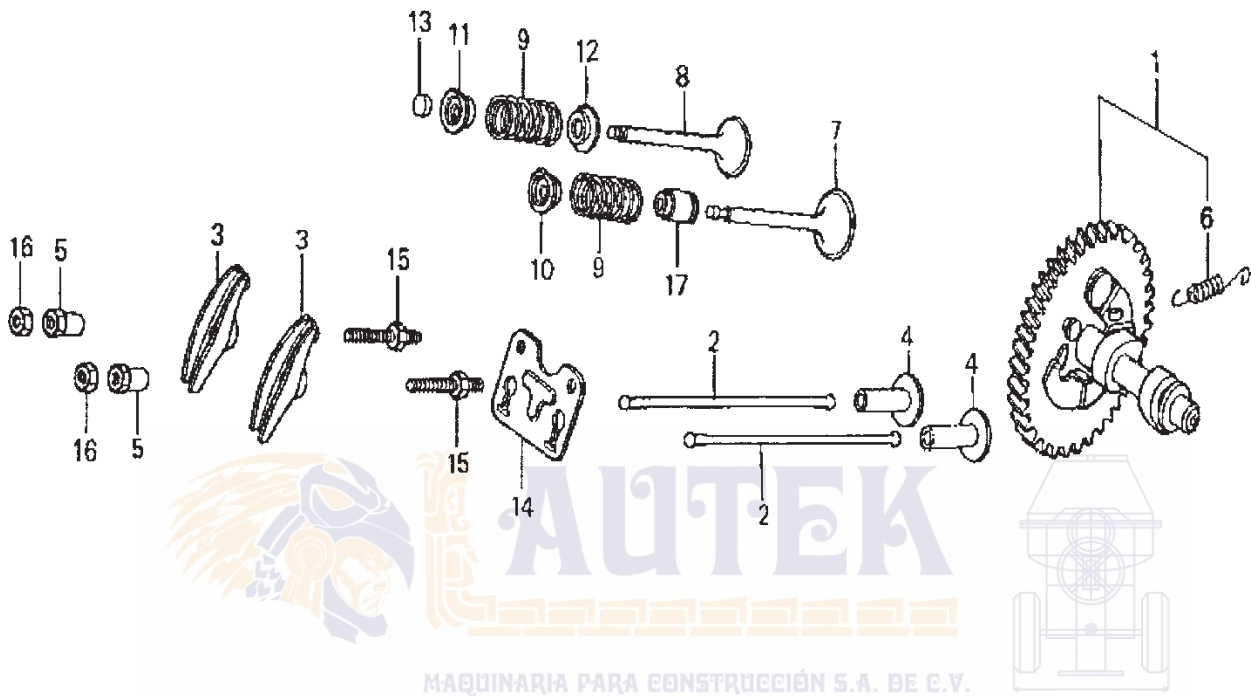

**HONDA GX390K1QA2/GX390U1QA2 — CAMSHAFT ASSY.**

<b>NO.</b>	<b>PART NO.</b>	<b>PART NAME</b>	<b>QTY.</b>	<b>REMARKS</b>
14	14100ZF6W0	CAMSHAFT ASSEMBLY .....	1 .....	INCLUDES ITEMS W/* SN 2391939 AND BELOW
14	14100ZF6W01	CAMSHAFT ASSEMBLY .....	1 .....	INCLUDES ITEMS W/* SN 2391940 AND ABOVE
1◇	14100ZF6W01	CAMSHAFT ASSEMBLY	1	
2	14410ZE3013	ROD, PUSH	2	
3	14431ZE2010	ARM, VALVE ROCKER.....	2.....	REPLACES 14431ZE2000
4	14441ZE2000	LIFTER, VALVE	2	
5	14451ZE1013	PIVOT, ROCKER ARM	2	
6*	14568ZE1000	SPRING, WEIGHT RETURN	1	
7	14711ZE3000	VALVE, INTAKE	1	
8	14721ZE3000	VALVE, EXHAUST	1	
9	14751ZE2003	SPRING, VALVE	2	
10	14771ZE2000	RETAINER, INTAKE VALVE SPRING	1	
11	14773ZE2000	RETAINER, EXHAUST VALVE SPRING	1	
12	14775ZE2010	SEAT, VALVE SPRING	1	
13	14781ZE2000	ROTATOR, VALVE	1	
14	14791ZE2010	PLATE, PUSH ROD GUIDE	1	
15	90012ZE0010	BOLT, PIVOT 8MM	2	
16	90206ZE1000	NUT, PIVOT ADJ.	2	
174	12209ZE8003	SEAL, VALVE STEM .....	1 .....	USE FROM ENGINE SN 3065844
17◇	12209ZE8003	SEAL, VALVE STEM	1	

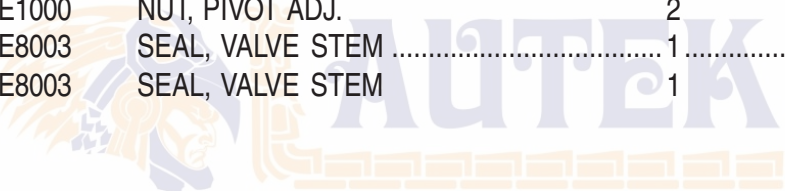

MAQUINARIA PARA CONSTRUCCIÓN S.A. DE C.V.



- 4 GX390K1QA2: Model EM120 December 2006 And Below
- ◇ GX340U1QA2: Model EM120 January 2007 And Above

**HONDA GX390K1QA2/GX390U1QA2 — PISTON ASSY.**

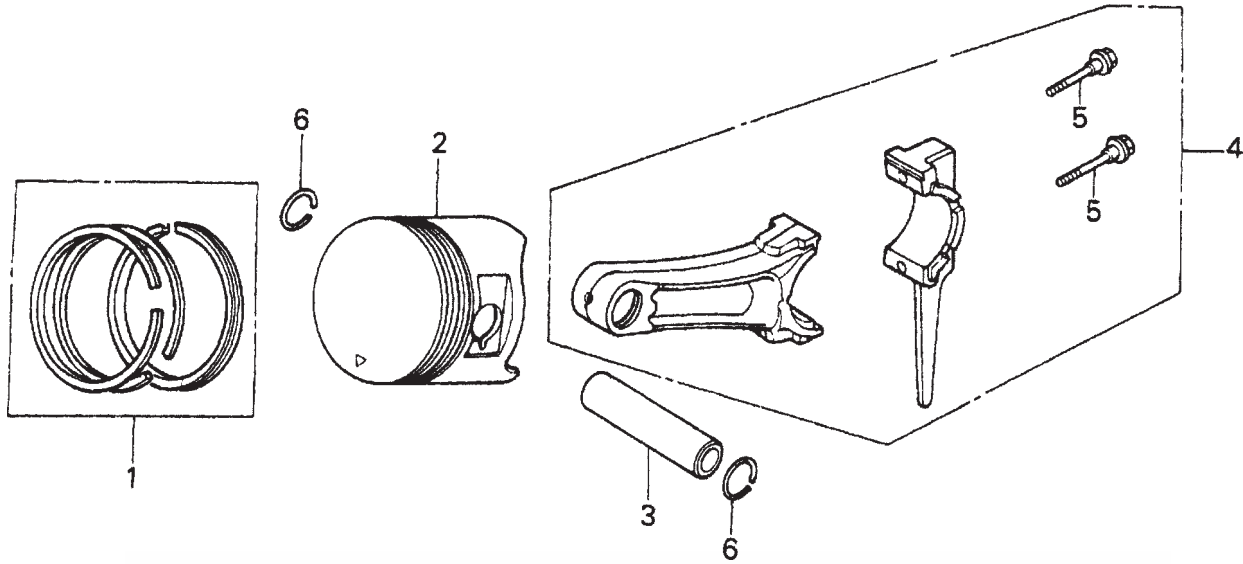

**HONDA GX390K1QA2/GX390U1QA2 — PISTON ASSY.**

<u>NO.</u>	<u>PART NO.</u>	<u>PART NAME</u>	<u>QTY.</u>	<u>REMARKS</u>
1	13010ZF6003	RING SET, PISTON (STD.)	1	
1	13010ZF6005	RING SET, PISTON (STD.)	1	
1	13011ZF6003	RING SET, PISTON (OS 0.25), OPT.	1	
1	13011ZF6005	RING SET, PISTON (OS 0.25), OPT.	1	
1	13012ZF6003	RING SET, PISTON (OS 0.50), OPT.	1	
1	13012ZF6005	RING SET, PISTON (OS 0.50), OPT.	1	
1	13012ZF6005	RING SET, PISTON (OS 0.50), OPT.	1	
1	13013ZF6003	RING SET, PISTON (0.75) NIP.,OPT.	1	
1	13013ZF6005	RING SET, PISTON (0.75) NIP.,OPT.	1	
2	13101ZF6W00	PISTON (STANDARD)	1	
2	13102ZF6W00	PISTON (OS 0.25), OPTIONAL	1	
2	13103ZF6W00	PISTON (OS 0.50), OPTIONAL	1	
2	13104ZF6W00	PISTON (0.75), OPTIONAL	1	
3	13111ZF6W00	PIN, PISTON	1	
44	13200ZE3010	ROD ASSY., CONNECTING (STD.) .....	1	INCLUDES ITEMS W/* ..... SN 3177434 AND BELOW
44	13200ZE3020	ROD ASSY., CONNECTING (STD.) .....	1	INCLUDES ITEMS W/* ..... SN 3177435 AND ABOVE
44	13200ZE3315	ROD ASSY., CONNECTING (US 0.25).....	1	INCLUDES ITEMS W/*
4◇	13200ZE3020	ROD ASSY., CONNECTING (STD.) .....	1	INCLUDES ITEMS W/*
4◇	13200ZE3315	ROD ASSY., CONNECTING (US 0.25).....	1	INCLUDES ITEMS W/*
5*	90001ZE8000	BOLT, CONNECTING ROD	2	
6	90601ZE3000	CLIP, PISTON PIN 20MM	2	

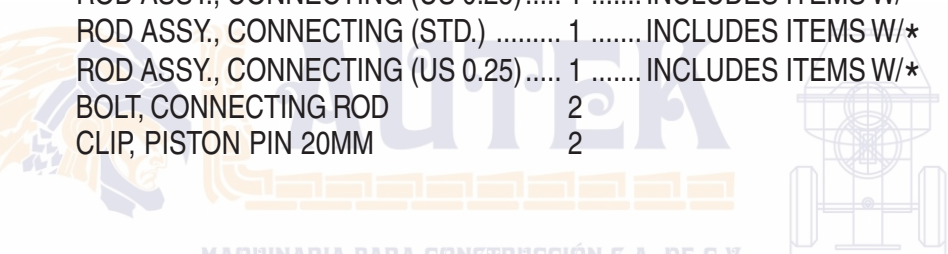

- 4 GX390K1QA2: Model EM120 December 2006 And Below
- ◇ GX340U1QA2: Model EM120 January 2007 And Above

**HONDA GX390K1QA2/GX390U1QA2 — CRANKCASE COVER ASSY.**

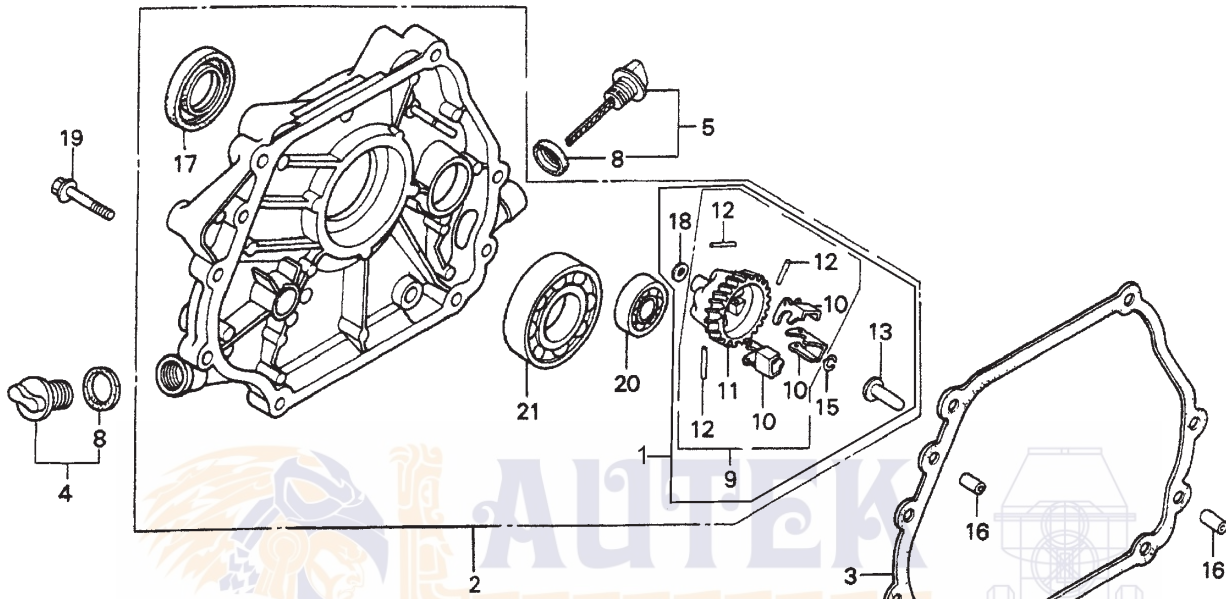

MAQUINARIA PARA CONSTRUCCIÓN S.A. DE C.V.

**HONDA GX390K1QA2/GX390U1QA2 — CRANKCASE COVER ASSY.**

<b>NO.</b>	<b>PART NO.</b>	<b>PART NAME</b>	<b>QTY.</b>	<b>REMARKS</b>
1*	06165ZE3000	GOVERNOR KIT (OPIONAL) .....	1 .....	INCLUDES ITEMS W/#
24	11300ZE3602	COVER ASSY., CRANKCASE (Q TYPE) .....	1 .....	INCLUDES ITEMS W/* ..... S/N 3287256 AND BELOW
24	11300ZE3604	COVER ASSY., CRANKCASE (Q TYPE) .....	1 .....	INCLUDES ITEMS W/* ..... S/N 3287257 AND ABOVE
20	11300ZE3604	COVER ASSY., CRANKCASE (Q TYPE)	1	
34	11381ZE3800	GASKET, CASE COVER .....	1 .....	S/N 2949254 AND BELOW
34	11381ZE3801	GASKET, CASE COVER .....	1 .....	S/N 2949255 AND ABOVE
30	11381ZE3801	GASKET, CASE COVER	1	
4	15600ZG4003	CAP ASSEMBLY, OIL FILLER .....	1 .....	INCLUDES ITEMS W/%
5	15600735003	CAP ASSEMBLY, OIL FILLER .....	1 .....	INCLUDES ITEMS W/%
8%	15625ZE1003	GASKET, OIL FILLER CAP	2	
9*#	16510ZE3000	GOVERNOR ASSEMBLY .....	1 .....	INCLUDES ITEMS W/+
10*#+	16511ZE8000	WEIGHT, GOVERNOR	3	
11*#+	16512ZE3000	HOLDER, GOVERNOR WEIGHT	1	
12*#+	16513ZE2000	PIN, GOVERNOR WEIGHT	3	
134 *#	16531ZE2000	SLIDER, GOVERNOR .....	1 .....	S/N 3287256 AND BELOW
134 *#	16531Z0A000	SLIDER, GOVERNOR .....	1 .....	S/N 3287257 AND ABOVE
130*#	16531Z0A000	SLIDER, GOVERNOR	1	
15*#	90602ZE1000	CLIP, GOVERNOR HOLDER	1	
16	90701HC4000	PIN, DOWEL 8X12	2	
17*	91201ZE3004	OIL SEAL 36X52X8	1	
18*#	9410106800	WASHER, PLAIN 6MM	1	
19	957010804000	BOLT, FLANGE 8X40	7	
20*	961006202000	BEARING, RADIAL BALL 6202	1	
21*	961006207000	BEARING, RADIAL BALL 6207	1	



- 4 GX390K1QA2: Model EM120 December 2006 And Below
- ◇ GX340U1QA2: Model EM120 January 2007 And Above

**HONDA GX390K1QA2/GX390U1QA2 — CRANKSHAFT ASSY.**

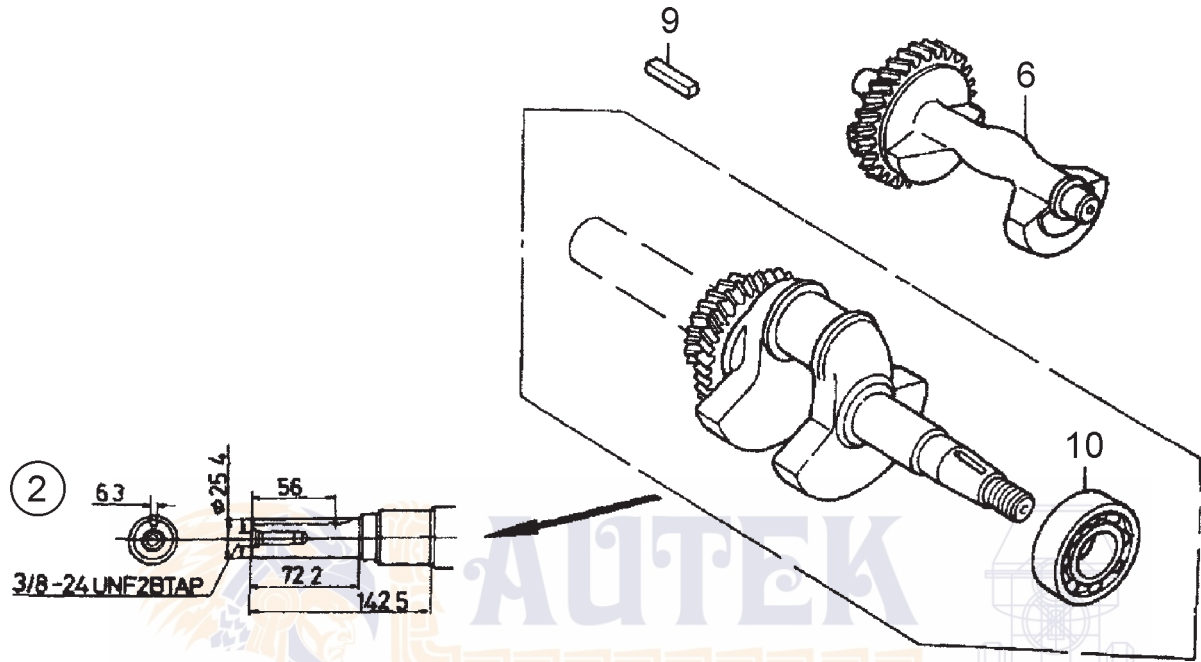

MAQUINARIA PARA CONSTRUCCIÓN S.A. DE C.V.

**HONDA GX390K1QA2/GX390U1QA2 — CRANKSHAFT ASSY.**

<u>NO.</u>	<u>PART NO.</u>	<u>PART NAME</u>	<u>QTY.</u>	<u>REMARKS</u>
24	13310ZF6W10	CRANKSHAFT, Q-TYPE .....	1 .....	INCLUDES ITEMS W/*
2◇	13310ZF6W11	CRANKSHAFT COMP. ....	1 .....	S/N 1113739 AND BELOW
2◇	13310ZF6W12	CRANKSHAFT COMP. ....	1 .....	S/N 1113740 AND ABOVE
6	13351ZE3010	WEIGHT, BALANCER	1	
9	90745ZE2600	KEY 6.3X6.3X43	1	
104*	91001ZF6003	BEARING, RADIAL BALL 6207S	1	
10◇*	91001ZF6003	BEARING, RADIAL BALL 6207S .....	1 .....	S/N 1113739 AND BELOW
10◇*	91001ZF6013	BEARING, RADIAL BALL 6207SH .....	1 .....	S/N 1113740 AND ABOVE



- 4 GX390K1QA2: Model EM120 December 2006 And Below
- ◇ GX340U1QA2: Model EM120 January 2007 And Above

**HONDA GX390K1QA2/GX390U1QA2 — CYLINDER BARREL ASSY.**

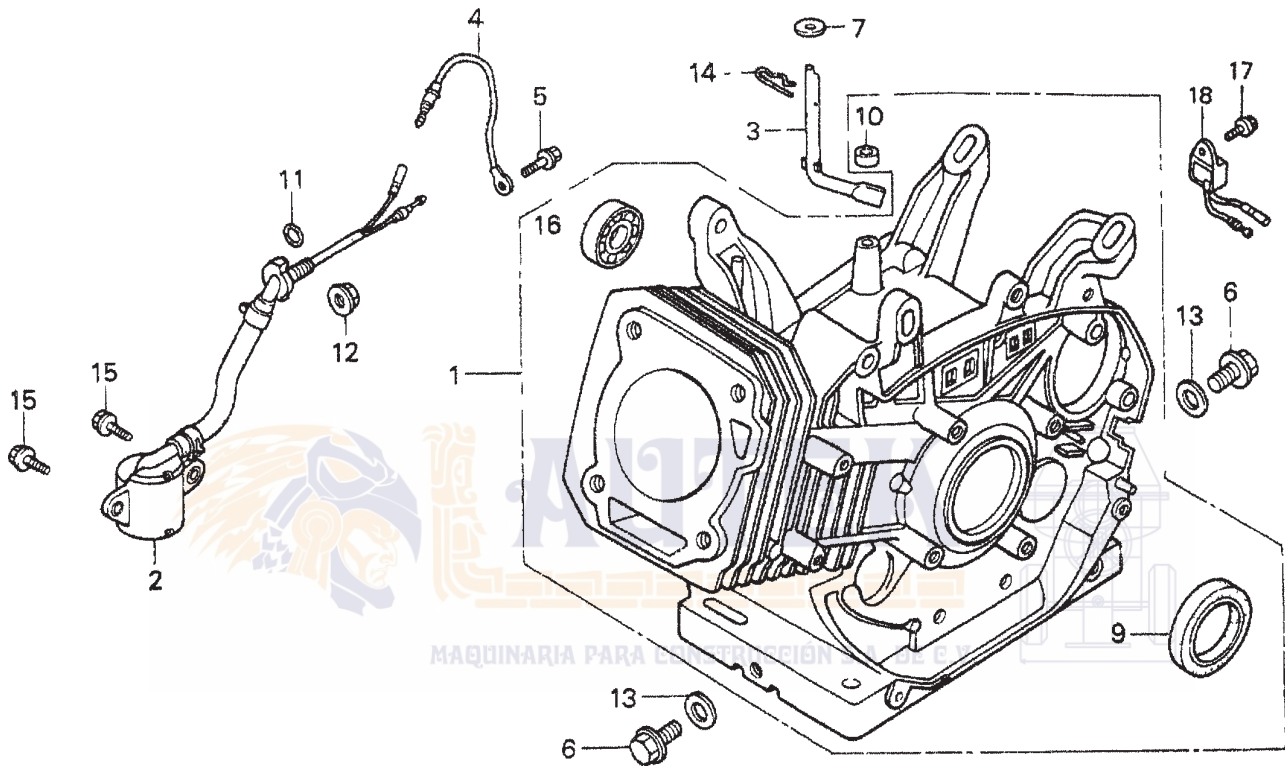

**HONDA GX390K1QA2/GX390U1QA2 — CYLINDER BARREL ASSY.**

<b>NO.</b>	<b>PART NO.</b>	<b>PART NAME</b>	<b>QTY.</b>	<b>REMARKS</b>
14	12000ZF6W12	BARREL ASSY., CYL. ALERT OIL .....	1 .....	INCLUDES ITEMS W/* ..... SN 3020570 AND BELOW
14	12000ZF6W13	BARREL ASSY., CYL. ALERT OIL .....	1 .....	INCLUDES ITEMS W/* ..... SN 3020571 AND ABOVE
10	12000ZF6417	BARREL ASSY., CYL. ALERT OIL .....	1 .....	INCLUDES ITEMS W/*
24	15510ZE2023	SWITCH ASSY., OIL LEVEL .....	1 .....	S/N 2334667 AND BELOW
24	15510ZE2033	SWITCH ASSY., OIL LEVEL .....	1 .....	2334668 ~ 2456575
24	15510ZE2043	SWITCH ASSY., OIL LEVEL .....	1 .....	REPLACES 15510ZE2033 ..... S/N 2456576 AND ABOVE
20	15510ZE2043	SWITCH ASSY., OIL LEVEL .....	1 .....	REPLACES 15510ZE2033 ..... S/N 1412956 AND BELOW
20	15510ZE2053	SWITCH ASSY., OIL LEVEL .....	1 .....	S/N 1412957 AND ABOVE
3	16541ZE3010	SHAFT, GOVERNOR ARM	1	
44	32197ZE2003	SUB-HARNESS .....	1 .....	USE UP TO ENGINE SN 2334667
54	90013883000	BOLT, FLANGE 6X12 (CT200) .....	1 .....	USE UP TO ENGINE SN 2334667
6	90131883000	BOLT, DRAIN PLUG 12 X 15	2	
7	90446KE1000	WASHER 8.2X17X0.8	1	
9*	91201ZE3004	OIL SEAL 35X52X8	1	
10*	91203952771	OIL SEAL 8X14X5	1	
11	91353671004	O- RING 13.5X1.5 (ARAI)	1	
12	9405010000	NUT, FLANGE 10mm.	1	
13	9410912000	WASHER, DRAIN PLUG 12mm.	2	
14	9425110000	PIN, LOCK 10mm.	1	
15	957010601200	BOLT, FLANGE 6X12	2	
16*	961006202000	BEARING, RADIAL BALL 6202	1	
174	90013883000	BOLT, FLANGE 6X12 (CT200) .....	1 .....	USE FROM ENGINE SN 2468555
170	90013883000	BOLT, FLANGE 6X12 (CT200)	1	
184	34150ZH7003	ALERT UNIT, OIL .....	1 .....	USE FROM ENGINE SN 2468555
180	34150ZH7003	ALERT UNIT, OIL .....	1 .....	S/N 1419413 AND BELOW
180	34150ZH7013	ALERT UNIT, OIL .....	1 .....	S/N 1419414 AND ABOVE

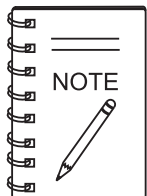
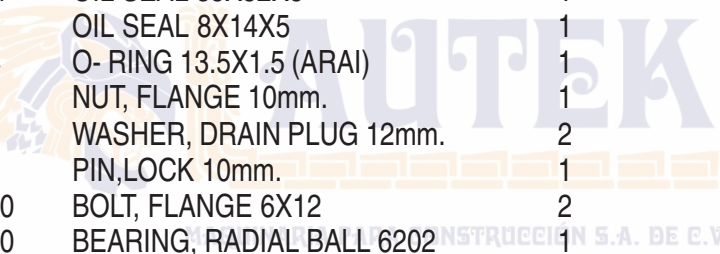

- 4 GX390K1QA2: Model EM120 December 2006 And Below
- ◇ GX340U1QA2: Model EM120 January 2007 And Above

**HONDA GX390K1QA2/GX390U1QA2 — CYLINDER HEAD ASSY.**

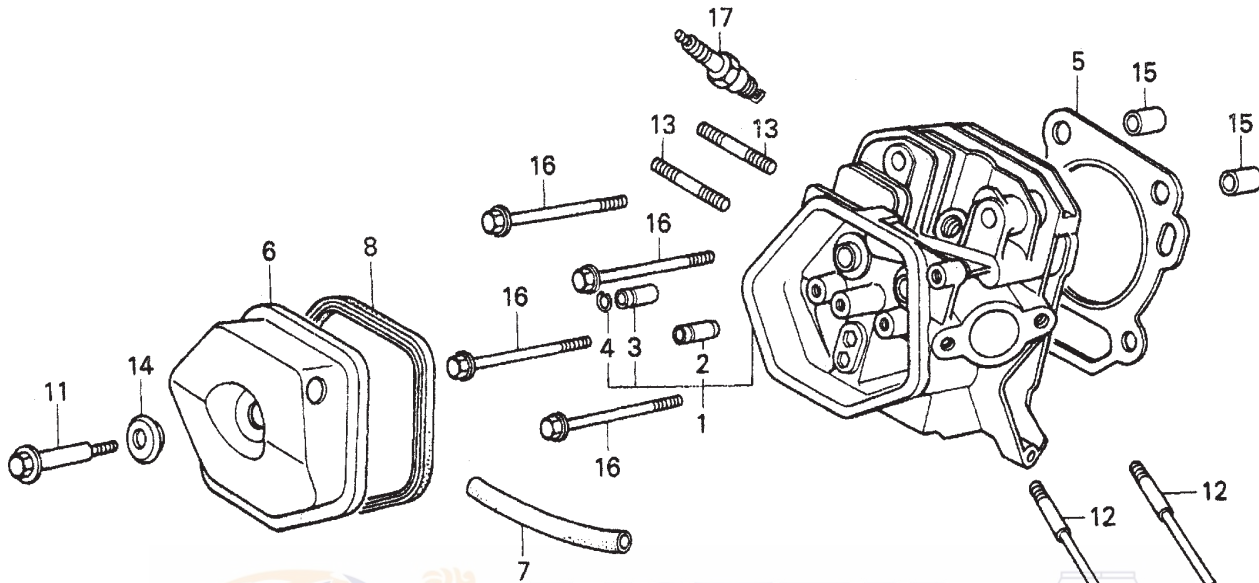

**HONDA GX390K1QA2/GX390U1QA2 — CYLINDER HEAD ASSY.**

<b>NO.</b>	<b>PART NO.</b>	<b>PART NAME</b>	<b>QTY.</b>	<b>REMARKS</b>
14	12200ZF6W01	CYLINDER HEAD .....	1	INCLUDES ITEMS W/*
10	12200ZF6406	CYLINDER HEAD .....	1	INCLUDES ITEMS W/*
2*	12204ZE2306	GUIDE, VALVE OS (OPTIONAL)	1	
3*	12205ZE2305	GUIDE, EX. VALVE OS (OPTIONAL)	1	
4*	12216ZE2300	CLIP, VALVE GUIDE	1	
5	12251ZF6W00	GASKET, CYLINDER HEAD	1	
64	12310ZE3791	COVER, HEAD .....	1	SN 2378736 AND BELOW
64	12310ZE2020	COVER, HEAD .....	1	SN 2378737 AND ABOVE
60	12310ZE2020	COVER, HEAD .....	1	
70	950051110530	TUBE, 11X105 .....	1	REPL. 950051100130M
74	950051110530	TUBE, 11X105 .....	1	SN 2368041 AND BELOW REPL. 950051100130M
74	12315ZE3840	TUBE, BREATHER .....	1	SN 2368042 AND ABOVE
8	12391ZE2020	GASKET, CYLINDER HEAD COVER	1	
11	90014ZE2000	BOLT, HEAD COVER	1	
12	90042ZE8000	BOLT, STUD 8X131.5	2	
134	90047ZE2000	BOLT 2, STUD 8X47	2	S/N 2638033 AND BELOW
134	92900080320E	BOLT 2, STUD 8X32 .....	2	REPLACES 90047ZE2000 S/N 2638034 AND ABOVE
130	92900080320E	BOLT 2, STUD 8X32	2	
14	90441ZE2010	WASHER, HEAD COVER	1	
15	9430112200	PIN A, DOWEL 12X20	2	
164	957251008000	BOLT, FLANGE 10X80	4	
160	957251008000	BOLT, FLANGE 10X80 .....	4	S/N 1411816 AND BELOW
160	957011008000	BOLT, FLANGE 10X80 .....	4	S/N 1411817 AND ABOVE
17	9807955846	SPARK PLUG BPR5ES (NGK), OPT.	1	
17	9807955855	SPARK PLUG W16EPR-U (DENSO), OPT.	1	
17	9807956846	SPARK PLUG BPR6ES (NGK)	1	
17	9807956855	SPARK PLUG W20EPR-U (DENSO)	1	



**4** GX390K1QA2: Model EM120 December 2006 And Below  
à **GX340U1QA2: Model EM120 January 2007 And Above**

**HONDA GX390K1QA2/GX390U1QA2 — FAN COVER ASSY.**

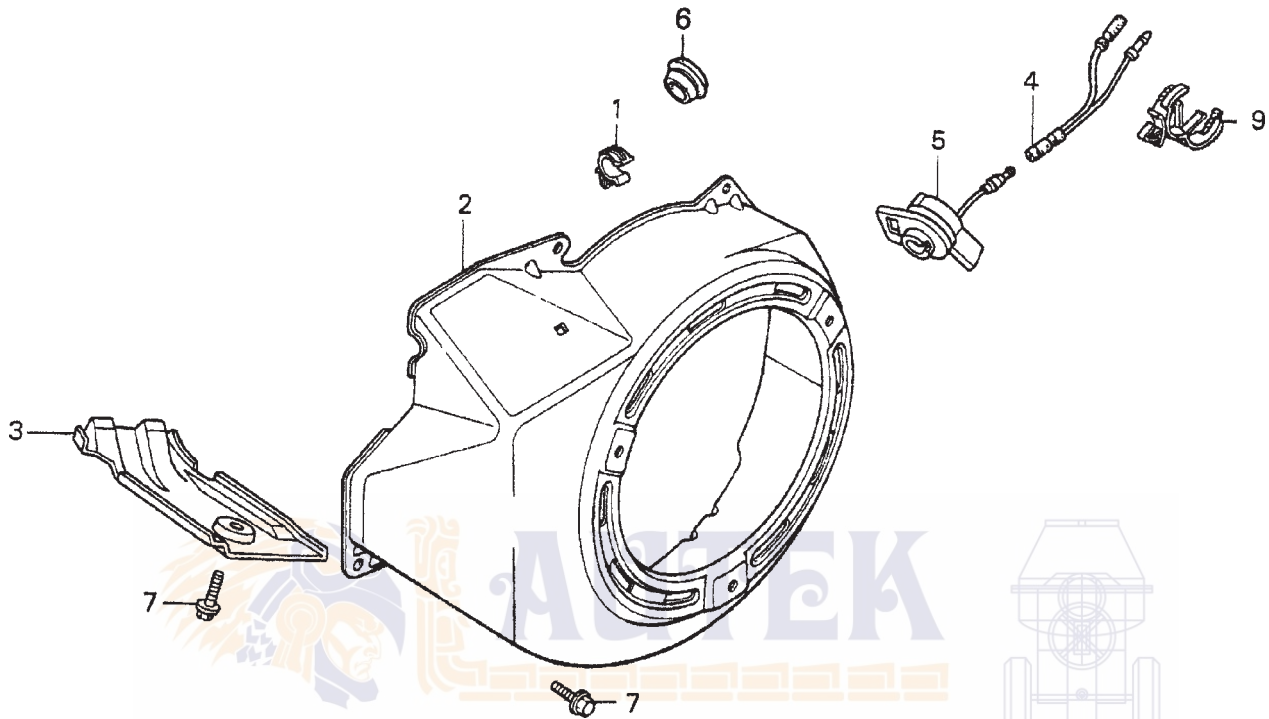

**HONDA GX390K1QA2/GX390U1QA2 — FAN COVER ASSY.**

<u>NO.</u>	<u>PART NO.</u>	<u>PART NAME</u>	<u>QTY.</u>	<u>REMARKS</u>
1	16731ZE2003	CLIP, TUBE	1	
2	19610ZE3010ZA	COVER, FAN *R280*, RED	1	
3	19631ZE3W00	SHROUD	1	
44	32197ZH8003	SUB-HARNESS .....	1	SN 2334667 AND BELOW
54	36100ZE1015	SWITCH ASSY., ENGINE STOP .....	1	SN 2334667 AND BELOW
54	36100ZH7003	SWITCH ASSY., ENGINE STOP .....	1	SN 2334668 AND ABOVE
5◇	36100ZF6P81	SWITCH ASSY., ENGINE STOP .....	1	SN 1412956 AND BELOW
5◇	36100ZF6P82	SWITCH ASSY., ENGINE STOP .....	1	SN 1412957 AND ABOVE
7	90013883000	BOLT, FLANGE 6X12 (CT200)	6	
94	90684ZA0601	CLIP, WIRE HARNESS	1	

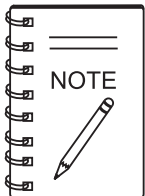

**AUTEK**  
 MAQUINARIA Y REPARACION S.A. DE C.V.



- 4 GX390K1QA2: Model EM120 December 2006 And Below
- ◇ GX340U1QA2: Model EM120 January 2007 And Above

**HONDA GX390K1QA2/GX390U1QA2 — FLYWHEEL ASSY.**

---

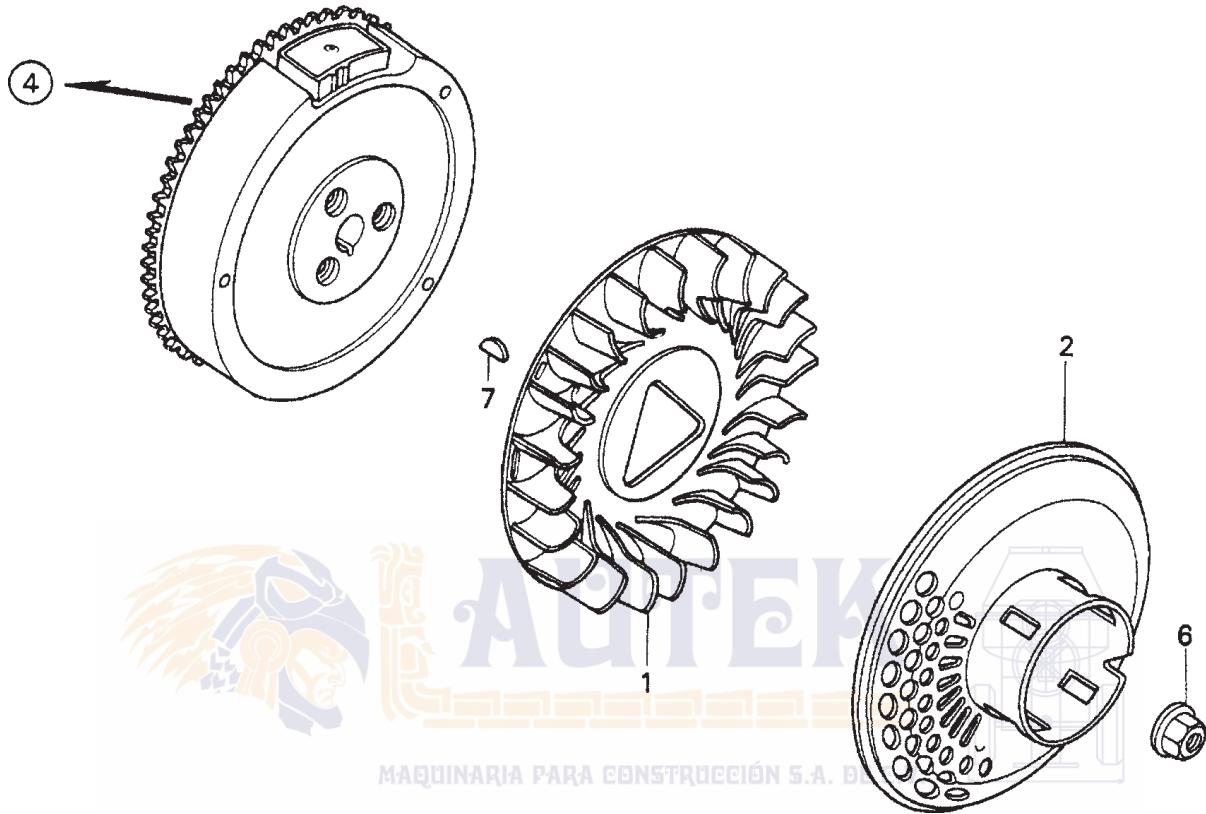

**HONDA GX390K1QA2/GX390U1QA2 — FLYWHEEL ASSY.**

<u>NO.</u>	<u>PART NO.</u>	<u>PART NAME</u>	<u>QTY.</u>	<u>REMARKS</u>
1	19511ZE3000	FAN, COOLING	1	
2	28450ZE3W11	PULLEY, STARTER (SCREEN GRID)	1	
4	31100ZE3701	FLYWHEEL	1	
64	90201ZE3790	NUT, SPECIAL 16MM .....	1	S/N 2263434 AND BELOW
64	90201ZE3V00	NUT, SPECIAL 16MM (1) .....	1	S/N 2263435 AND ABOVE
6◇	90201ZE3V00	NUT, SPECIAL 16MM (1) .....	1	S/N 1317976 AND BELOW
6◇	90201ZE3790	NUT, SPECIAL 16MM .....	1	S/N 1317977 AND ABOVE
7	90741ZE2000	KEY, SPECIAL WOODRUFF 25X18	1	



- 4 GX390K1QA2: Model EM120 December 2006 And Below
- ◇ GX340U1QA2: Model EM120 January 2007 And Above



MAQUINARIA PARA CONSTRUCCIÓN S.A. DE C.V.



**HONDA GX390K1QA2/GX390U1QA2 — IGNITION COIL ASSY.**

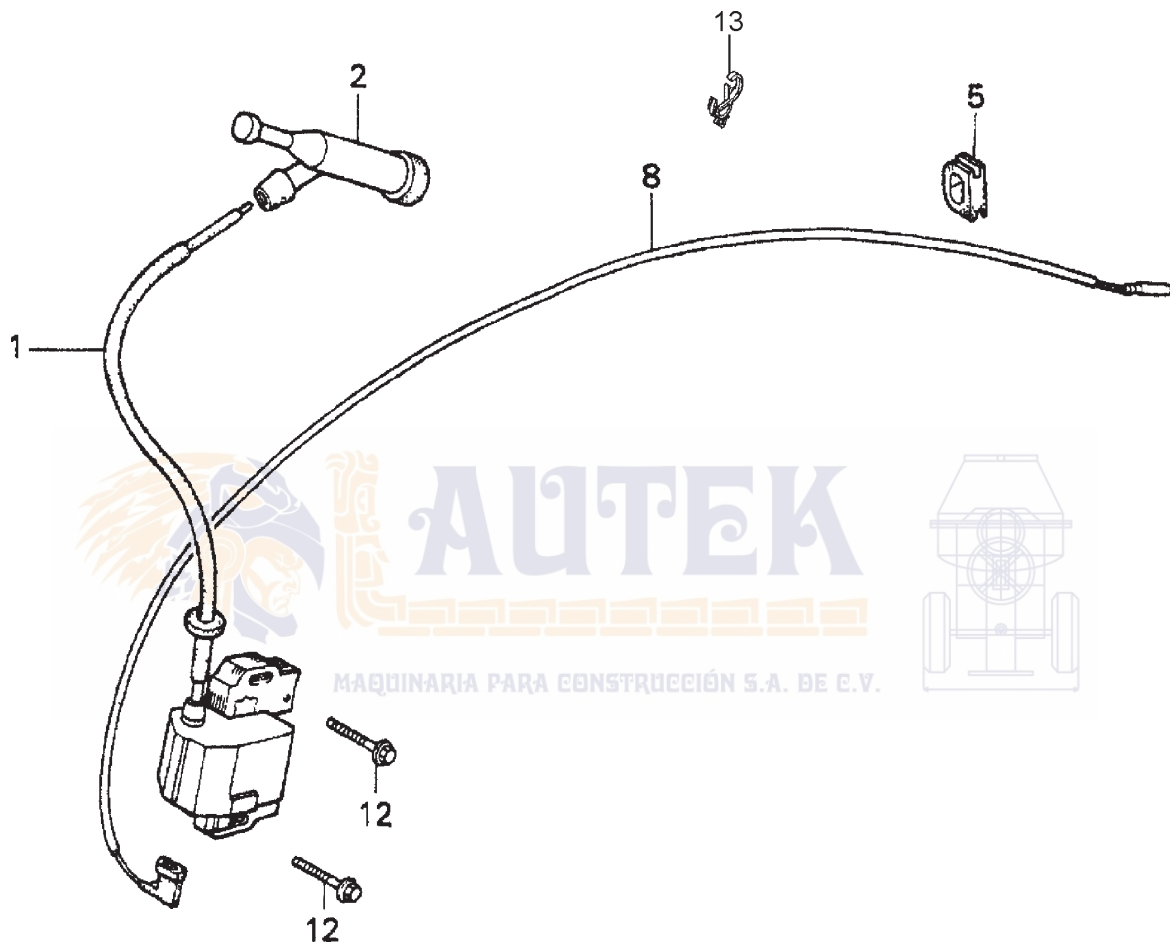

**HONDA GX390K1QA2/GX390U1QA2 — IGNITION COIL ASSY.**

<u>NO.</u>	<u>PART NO.</u>	<u>PART NAME</u>	<u>QTY.</u>	<u>REMARKS</u>
14	30500ZF6W02	COIL ASSEMBLY, IGNITION .....	1 .....	REPLACES 305007E2023
1◇	30500ZF6W02	COIL ASSEMBLY, IGNITION .....	1 .....	S/N 1411816 AND BELOW
1◇	30500ZF6W03	COIL ASSEMBLY, IGNITION .....	1 .....	S/N 1411817 AND ABOVE
2	30700ZE1013	CAP ASSEMBLY, NOISE SUPPRESSOR	1	
5	31512ZE2000	GROMMET, WIRE	1	
8	36101ZE2701	WIRE, STOP SWITCH 430MM	1	
12	90015883000	BOLT, FLANGE 6X28	2	
13◇	90684ZA0601	CLIP, HARNESS	1	



- 4 GX390K1QA2: Model EM120 December 2006 And Below
- ◇ GX340U1QA2: Model EM120 January 2007 And Above



MAQUINARIA PARA CONSTRUCCIÓN S.A. DE C.V.



HONDA GX390K1QA2/GX390U1QA2 — CARBURETOR ASSY.

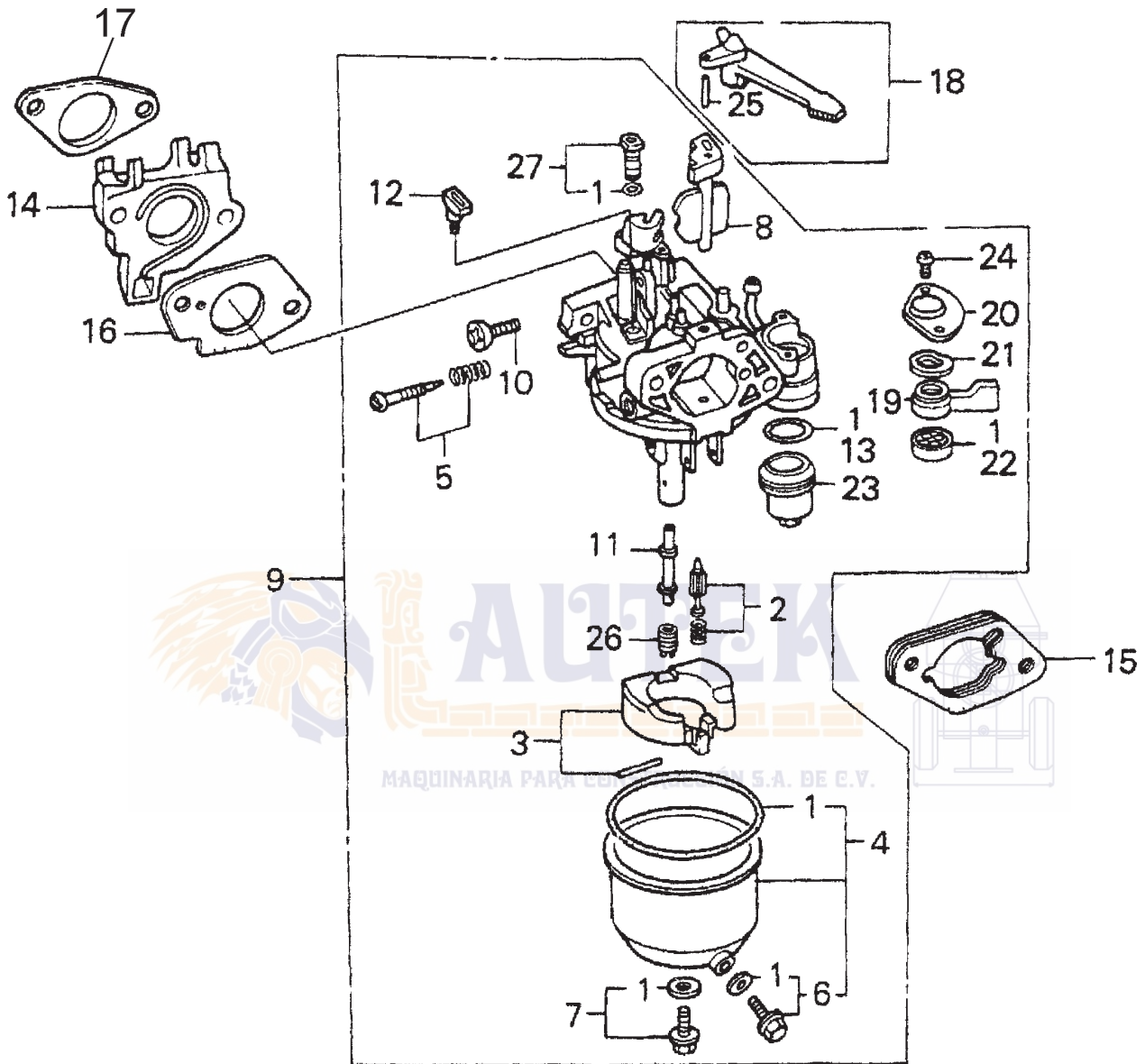

**HONDA GX390K1QA2/GX390U1QA2 — CARBURETOR ASSY.**

CARBURETOR ASSY.

<b>NO.</b>	<b>PART NO.</b>	<b>PART NAME</b>	<b>QTY.</b>	<b>REMARKS</b>
1#%	16010ZE2812	GASKET SET .....	1	INCLUDES ITEM W/&
2*	16011ZA0931	VALVE SET, FLOAT	1	
3*	16013ZA0931	FLOAT SET	1	
44*	16015ZE2005	CHAMBER SET, FLOAT .....	1	INCLUDES ITEMS W/% S/N BE85B A AND BELOW
44*	16015ZE8005	CHAMBER SET, FLOAT .....	1	INCLUDES ITEMS W/% S/N BE85B B AND ABOVE
4◇*	16015ZE8005	CHAMBER SET, FLOAT	1	
5*	16016ZH7W01	SCREW SET	1	
6*%	16024ZE1811	SCREW SET, DRAIN .....	1	INCLUDES ITEMS W/#
7*	16028ZE0005	SCREW SET B .....	1	INCLUDES ITEMS W/#
8*	16044ZE3W20	CHOKE SET	1	
94	16100ZF6V00	CARBURETOR ASSY., BE85BA .....	1	INCLUDES ITEMS W/* S/N 2255423 AND BELOW
94	16100ZF6V01	CARBURETOR ASSY., BE85B B .....	1	INCLUDES ITEMS W/* S/N 2255424 AND ABOVE
9◇	16100ZF6V01	CARBURETOR ASSY., BE85B B .....	1	INCLUDES ITEMS W/*
10*	16124ZE0005	SCREW, THROTTLE STOP	1	
11*	16166ZF6V00	NOZZLE, MAIN	1	
12*	16172ZE3W10	COLLAR, SET	1	
13* &	16173001004	GASKET, FUEL STRAINER CUP	1	
14	16211ZF6000	INSULATOR, CARBURETOR	1	
15	16220ZA0702	SPACER, CARBURETOR	1	
16	16221ZF6800	GASKET, CARBURETOR	1	
17	16223ZE3W00	GASKET, INSULATOR	1	
18	16610ZE1000	LEVER, CHOKE (STANDARD) .....	1	INCLUDES ITEMS W/+



- 4 GX390K1QA2: Model EM120 December 2006 And Below
- ◇ GX340U1QA2: Model EM120 January 2007 And Above

**HONDA GX390K1QA2/GX390U1QA2 — MUFFLER ASSY.**

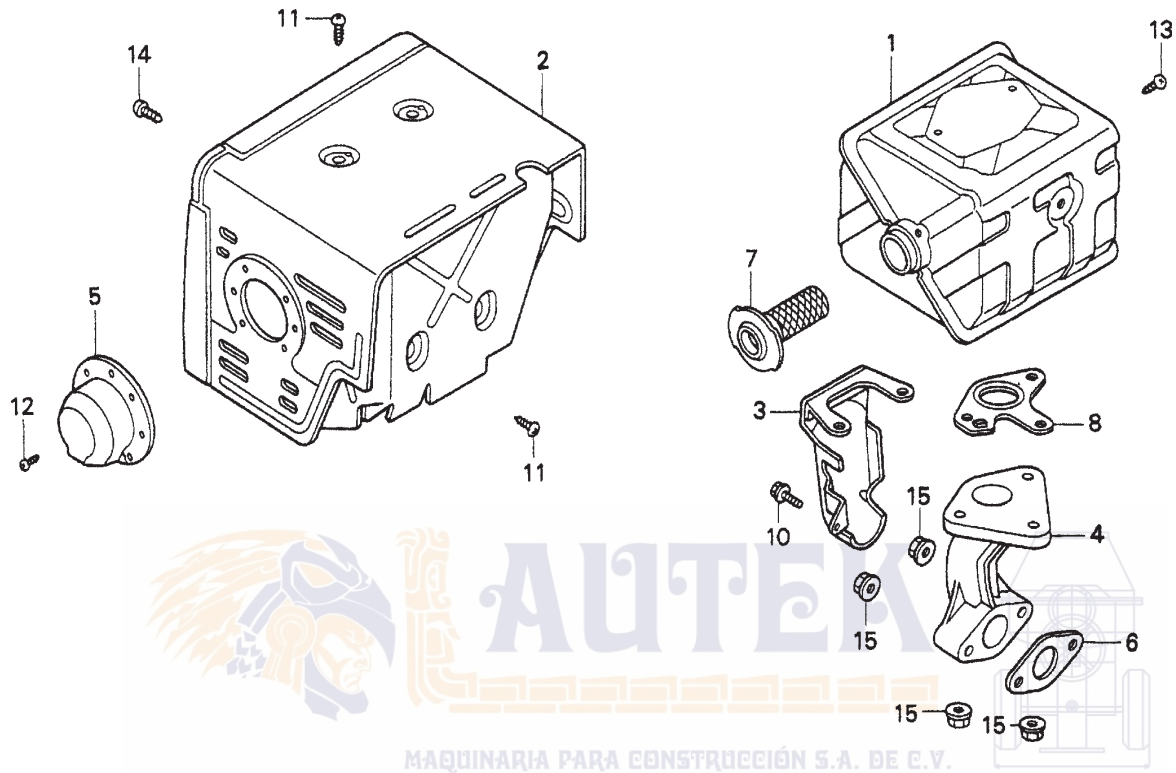

**HONDA GX390K1QA2/GX390U1QA2 — MUFFLER ASSY.**

<u>NO.</u>	<u>PART NO.</u>	<u>PART NAME</u>	<u>QTY.</u>	<u>REMARKS</u>
1	18310ZE2W61	MUFFLER 100DB	1	
2	18320ZE2W61	PROTECTOR, MUFFLER	1	
3	18323ZE3W40	PROTECTOR, EXHAUST PIPE	1	
4	18330ZE2W00	PIPE, EXHAUST	1	
54	18331ZE3810	CAP, MUFFLER	1	
5◇	18331ZE3810	CAP, MUFFLER .....	1	S/N 1166160 AND BELOW
5◇	18331ZE3811	CAP, MUFFLER .....	1	S/N 1166161 AND ABOVE
64	18333ZE3800	GASKET, EXHAUST PIPE .....	1	S/N 2275744 AND BELOW
64	18333ZK6Y00	GASKET, EXHAUST PIPE .....	1	2275745 ~ 2638033
64	18333ZF6W01	GASKET, EXHAUST PIPE .....	1	S/N 2638034 AND ABOVE
6◇	18333ZE6W01	GASKET, EXHAUST PIPE	1	
7	18355ZE2W00	ARRESTER, SPARK	1	
8	18381ZE2W10	GASKET, MUFFLER (ARRESTER)	1	
10	90013883000	BOLT, FLANGE 6X12 (CT200)	1	
11	90050ZE1000	SCREW, TAPPING 5X8	4	
12	90055ZE1000	SCREW, TAPPING 4X6	3	
13	90055ZE1000	SCREW, TAPPING 4X6	1	
14	90006ZE2000	SCREW, TAPPING 6X10	1	
15	9405008000	NUT, FLANGE 8MM	5	



MAQUINARIA PARA CONSTRUCCIÓN S.A. DE C.V.



- 4 GX390K1QA2: Model EM120 December 2006 And Below
- ◇ GX340U1QA2: Model EM120 January 2007 And Above

**HONDA GX390K1QA2/GX390U1QA2 — RECOIL STARTER ASSY.**

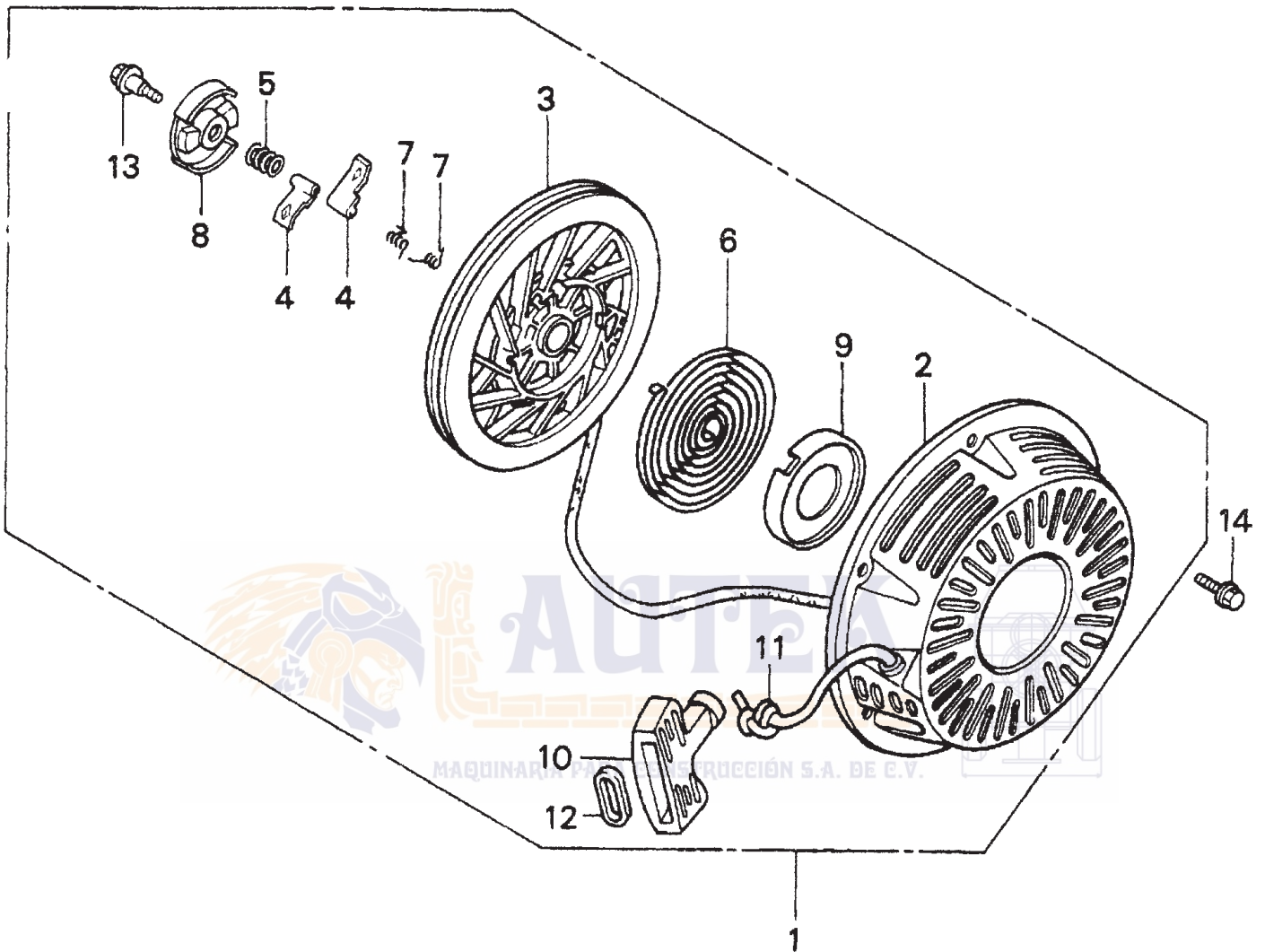

**HONDA GX390K1QA2/GX390U1QA2 — RECOIL STARTER ASSY.**

<b>NO.</b>	<b>PART NO.</b>	<b>PART NAME</b>	<b>QTY.</b>	<b>REMARKS</b>
14	28400ZE3W01ZA	STARTER ASSY., RECOIL *R8*, RED. ....	1	INCLUDES ITEMS W/*
1◇	28400ZE3W01ZP	STARTER ASSY., RECOIL *R280*, RED. ....	1	INCLUDES ITEMS W/*
24*	28410ZE3W01ZA	CASE, RECOIL STARTER *R8*, RED	1	
2◇*	28410ZE3W01ZP	CASE, RECOIL STARTER *R280*, RED	1	
3*	28421ZE3W01	PULLEY, RECOIL STARTER	1	
4*	28422ZE2W01	RATCHET, STARTER	2	
5*	28441ZE2W01	SPRING, FRICTION	1	
6*	28442ZE2W01	SPRING, STARTER RETURN	1	
7*	28443ZE2W01	SPRING, RATCHET	2	
8*	28444ZE2W01	RETAINER, SPRING	1	
9*	28445ZE2W01	HOLDER, SPRING	1	
10*	28461ZE2W02	GRIP, STARTER	1	
11*	28462ZE3W01	ROPE, RECOIL STARTER	1	
12◇*	28469ZE2W01	GRIP, REINFORCEMENT .....	1	UP TO ENG. S/N 584635
13*	90004ZE2W01	SCREW, CENTER	1	
14	90008ZE2003	BOLT, FLANGE 6X10	3	



MAQUINARIA PARA CONSTRUCCIÓN S.A. DE C.V.



- 4 GX390K1QA2: Model EM120 December 2006 And Below
- ◇ GX340U1QA2: Model EM120 January 2007 And Above

**HONDA GX390K1QA2/GX390U1QA2— CONTROL ASSY.**

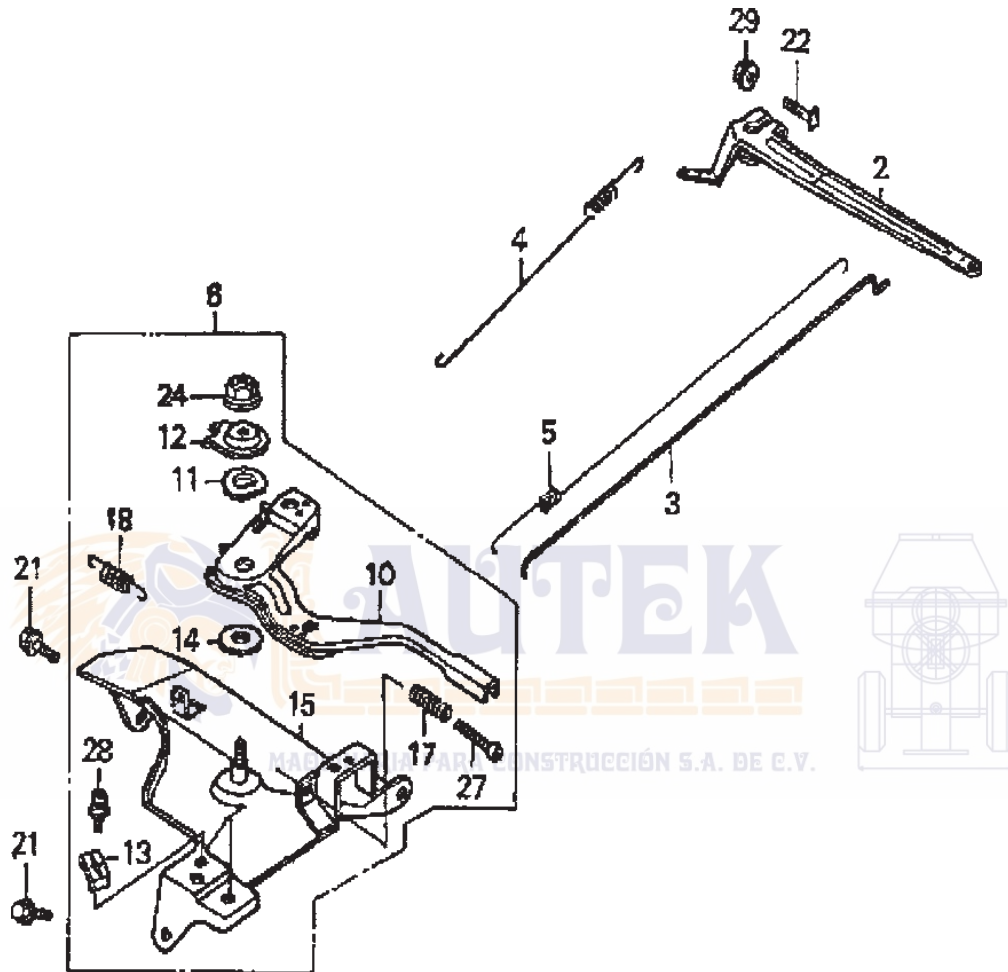

**HONDA GX390K1QA2/GX390U1QA2— CONTROL ASSY.**

<u>NO.</u>	<u>PART NO.</u>	<u>PART NAME</u>	<u>QTY.</u>	<u>REMARKS</u>
2	16551ZE3000	ARM, GOVERNOR	1	
3	16555ZE3000	ROD, GOVERNOR	1	
4	16561ZE3000	SPRING, GOVERNOR	1	
5	16562ZE3000	SPRING, THROTTLE RETURN	1	
6	16570ZE3W20	CONTROL ASSEMBLY, REMOTE .....	1	INCLUDES ITEMS W/*
10*	16571ZE3W00	LEVER, CONTROL	1	
11*	16574ZE1000	SPRING, LEVER	1	
12*	1675ZE2W00	WASHER, CONTROL LEVER	1	
13*	16576891000	HOLDER, CABLE	1	
14*	16578ZE1000	SPACER, CONTROL LEVER	1	
15*	16581ZE3W00	BASE, CONTROL (###)	1	
17*	16584883300	SPRING, CONTROL ADJUSTING	1	
18*	16592883310	SPRING, CABLE RETURN	1	
21	90013883000	BOLT, FLANGE (6X12) (CT200)	2	
22	90015ZE5010	BOLT, GOVERNOR ARM	1	
24*	90114SA0000	NUT, SELF-LOCK (6MM)	1	
27*	93500050320A	SCREW, PAN (5X32)	1	
28*	93500050160A	SCREW, PAN (5X16)	1	
29	9405006000	NUT, FLANGE (6MM)	1	



**HONDA GX390K1QA2/GX390U1QA2 — FUEL TANK ASSY.**

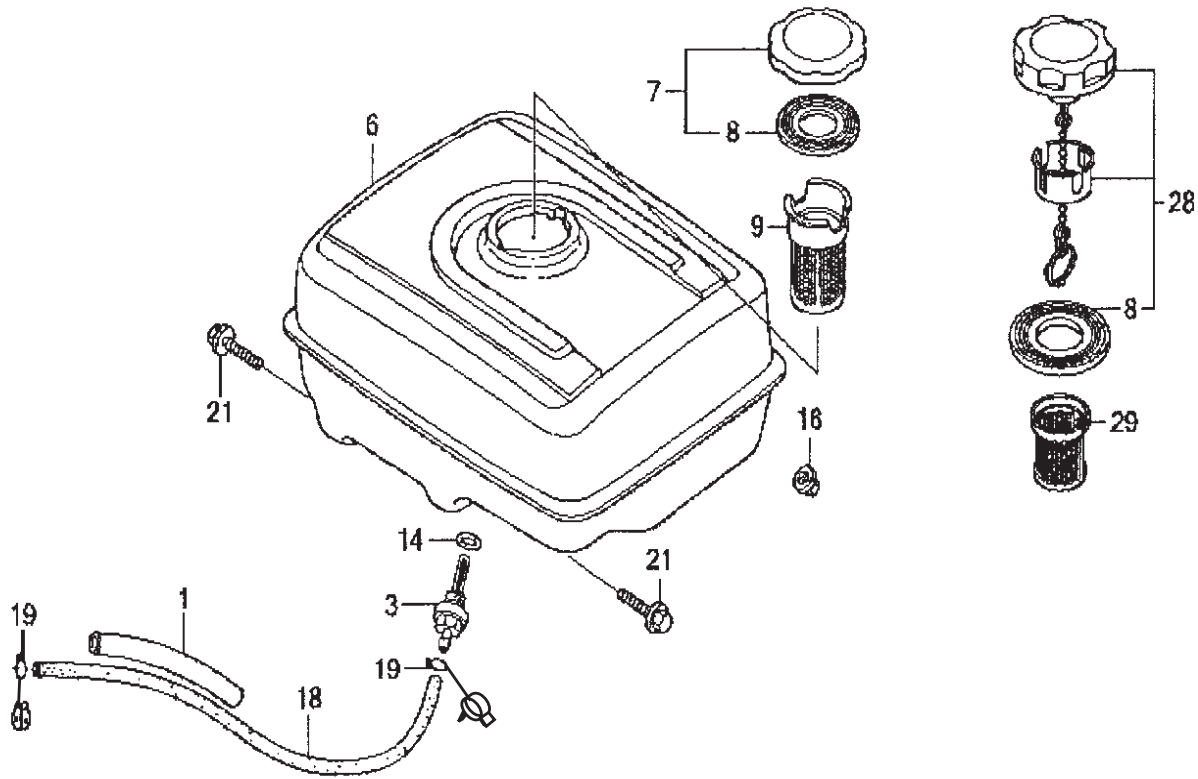

**HONDA GX390K1QA2/GX390U1QA2 — FUEL TANK ASSY.**

<u>NO.</u>	<u>PART NO.</u>	<u>PART NAME</u>	<u>QTY.</u>	<u>REMARKS</u>
1	16854ZH8000	RUBBER, SUPPORTER (107MM)	1	
3	16955ZE1000	JOINT, FUEL TANK	1	
64	17510ZE3010ZA	TANK, FUEL *NH31*	1	
64	17510ZE3010ZB	TANK, FUEL *NH1*	1	
64	17510ZE3010ZA	TANK, FUEL *T34*	1	
6◇	17510ZE3020ZA	TANK, FUEL *NH31* .....	1 .....	S/N 1213085 AND BELOW
6◇	17510ZE3020ZB	TANK, FUEL *NH1* .....	1 .....	S/N 1213085 AND BELOW
6◇	17510ZE3020ZD	TANK, FUEL *T34* .....	1 .....	S/N 1213085 AND BELOW
6◇	17510ZE3800ZA	TANK, FUEL *NH1* .....	1 .....	1213086 ~ 1383799
6◇	17510ZE3800ZC	TANK, FUEL *NH31* .....	1 .....	1213086 ~ 1383799
6◇	17510ZE3800ZE	TANK, FUEL *T34* .....	1 .....	1213086 ~ 1383799
6◇	17510ZE3801ZA	TANK, FUEL *NH1* .....	1 .....	S/N 1383800 AND ABOVE
6◇	17510ZE3801ZC	TANK, FUEL *NH31* .....	1 .....	S/N 1383800 AND ABOVE
6◇	17510ZE3801ZE	TANK, FUEL *T34* .....	1 .....	S/N 1383800 AND ABOVE
74	17620ZH013	CAP COMP., FUEL FILLER .....	1 .....	S/N 1383800 AND ABOVE
74	17620ZH023	CAP COMP., FUEL FILLER (BLACK) .....	1 .....	S/N 1383800 AND ABOVE
7◇	17620Z0T305	CAP COMP., FUEL FILLER .....	1 .....	S/N 1530148 AND BELOW ( CHROME PLATED)
84	17631ZH7003	FUEL, FILLER CAP (39X58X3)	1	
8◇	17631Z0T812	FUEL, FILLER CAP (39X62X3) .....	1 .....	S/N 1530148 AND BELOW
8◇	17631Z4H800	FUEL, FILLER CAP (39X62X3) .....	1 .....	S/N 1530149 ~ 1552033
8◇	17631Z0T801	FUEL, FILLER CAP (39X62X3) .....	1 .....	S/N 1552034 AND ABOVE
94	17672ZE2W01	FILTER, FUEL	1	
9◇	17672ZE2W01	FILTER, FUEL .....	1 .....	S/N 1530148 AND BELOW
14	91353671004	O-RING 14MM (NOK)	1	
16	9405008000	NUT, FLANGE 8MM	2	
184	950014523540	TUBE, FUEL 4.5 X 235 .....	1 .....	REPL. 950014500160M
18◇	950014523540	TUBE, FUEL 4.5 X 235 .....	1 .....	S/N 1105013 AND BELOW REPL. 950014500160M
18◇	91424Z5L801	TUBE, FUEL 4.5 X 235 (FKM) .....	1 .....	S/N 1105014 AND ABOVE
194	9500202080	CLIP, TUBE (B8)	2	
19◇	9500202080	CLIP, TUBE (B8) .....	2 .....	S/N 1105013 AND BELOW
19◇	950024080008	CLAMP, TUBE (D8) .....	2 .....	S/N 1105014 AND ABOVE
21	957010802500	BOLT, FLANGE 8 X 25	2	
28◇	17620Z4H010	CAP COMP., FUEL FILLER .....	1 .....	1530149 ~ 1552033
28◇	17620Z4H020	CAP COMP., FUEL FILLER .....	1 .....	1552034 AND ABOVE
29◇	17672Z4H000	FILTER, FUEL .....	1 .....	1530149 AND ABOVE

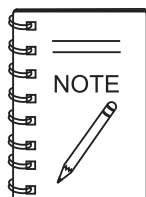

- 4 GX390K1QA2: Model EM120 December 2006 And Below
- ◇ GX340U1QA2: Model EM120 January 2007 And Above

**AUTEK MAQUINARIA 5392 7077**  
**HONDA GX390K1QA2 — GASKET KIT ASSY.**

---

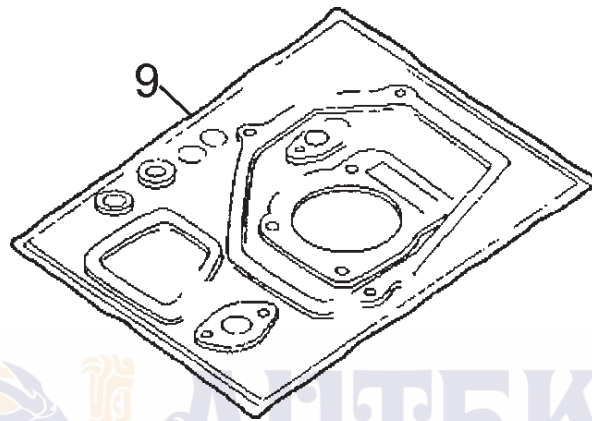

**HONDA GX390K1QA2 — GASKET KIT ASSY.**

<u>NO.</u>	<u>PART NO.</u>	<u>PART NAME</u>	<u>QTY.</u>	<u>REMARKS</u>
1*	11381ZE3800	GASKET, CASE COVER	1	
3*	12251ZF6W00	GASKET, CYLINDER HEAD	1	
4*	12391ZE2020	GASKET, CYLINDER HEAD COVER	1	
5*	16221ZF6800	GASKET, CARBURETOR	1	
6*	16223ZE3W00	GASKET, INSULATOR	1	
7*	18333ZF6W01	GASKET, EXHAUST PIPE	1	
8*	18381ZE2W10	GASKET, MUFFLER (ARRESTER)	1	
9	061A1Z6700	GASKET KIT .....	1	INCLUDES ITEMS W/*
		.....		REPLACES 06111ZF6407
		.....		S/N 2949254



**HONDA GX390K1QA2/GX390U1QA2 — LABELS ASSY.**

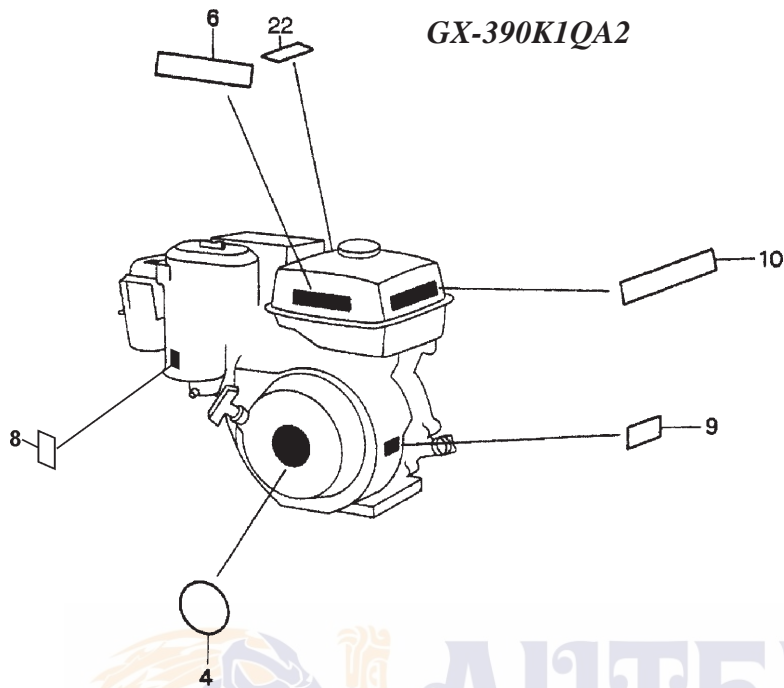

*GX-390U1QA2*

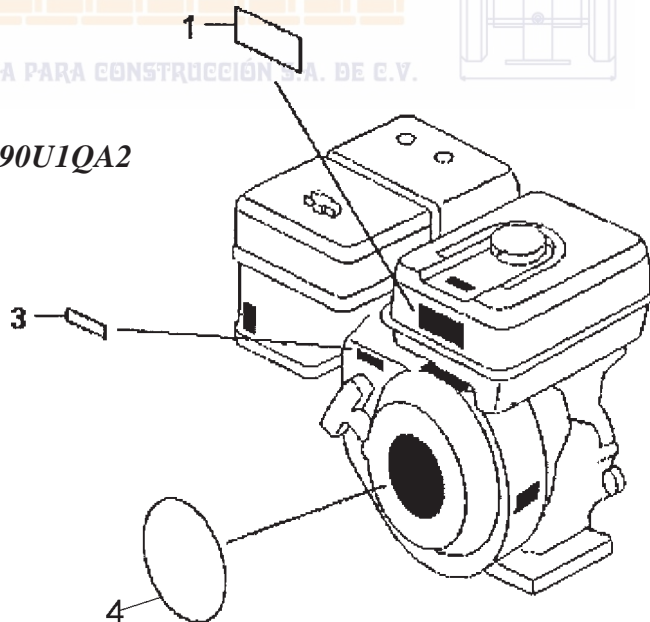

**HONDA GX390K1QA2/GX390U1QA2 — LABELS ASSY.**

<u>NO.</u>	<u>PART NO.</u>	<u>PART NAME</u>	<u>QTY.</u>	<u>REMARKS</u>
1◇	87516ZH7000	MARK, OPERATOR	1	
3◇	87532ZH7000	MARK,, THROTTLE INDICATION	1	
44	87521ZF6W01	EMBLEM .....	1 .....	S/N 3249629 AND BELOW
44	87521ZF6W02	EMBLEM .....	1 .....	S/N 3249630 AND ABOVE
4◇	87521ZF6W03	EMBLEM .....	1 .....	S/N 1398206 AND BELOW
4◇	87521ZF6W04	EMBLEM .....	1 .....	S/N 1398207 AND ABOVE
64	87522ZH9010	LABEL, CAUTION	1	
84	87528ZE2810	MARK, CHOKE (ORANGE)	1	
94	87530ZF6W10	LABEL, SPECIFICATION .....	1 .....	TO ENGINE S/N 2172909
104	87532ZH8810	MARK, OIL ALERT (E)	1	
224	87586ZH7W00	LABEL, FUEL CAUTION .....	1 .....	TO ENGINE S/N 2166102



- 4 GX390K1QA2: Model EM120 December 2006 And Below
- ◇ GX340U1QA2: Model EM120 January 2007 And Above



MAQUINARIA PARA CONSTRUCCIÓN S.A. DE C.V.



**TERMS AND CONDITIONS OF SALE — PARTS****PAYMENT TERMS**

Terms of payment for parts are net 30 days.

**FREIGHT POLICY**

All parts orders will be shipped collect or prepaid with the charges added to the invoice. All shipments are F.O.B. point of origin. Multiquip's responsibility ceases when a signed manifest has been obtained from the carrier, and any claim for shortage or damage must be settled between the consignee and the carrier.

**MINIMUM ORDER**

The minimum charge for orders from Multiquip is \$15.00 net. Customers will be asked for instructions regarding handling of orders not meeting this requirement.

**RETURNED GOODS POLICY**

Return shipments will be accepted and credit will be allowed, subject to the following provisions:

1. A Returned Material Authorization must be approved by Multiquip prior to shipment.
2. To obtain a Return Material Authorization, a list must be provided to Multiquip Parts Sales that defines item numbers, quantities, and descriptions of the items to be returned.
  - a. The parts numbers and descriptions must match the current parts price list.
  - b. The list must be typed or computer generated.
  - c. The list must state the reason(s) for the return.
  - d. The list must reference the sales order(s) or invoice(s) under which the items were originally purchased.
  - e. The list must include the name and phone number of the person requesting the RMA.
3. A copy of the Return Material Authorization must accompany the return shipment.
4. Freight is at the sender's expense. All parts must be returned freight prepaid to Multiquip's designated receiving point.

5. Parts must be in new and resalable condition, in the original Multiquip package (if any), and with Multiquip part numbers clearly marked.
6. The following items are not returnable:
  - a. Obsolete parts. (If an item is in the price book and shows as being replaced by another item, it is obsolete.)
  - b. Any parts with a limited shelf life (such as gaskets, seals, "O" rings, and other rubber parts) that were purchased more than six months prior to the return date.
  - c. Any line item with an extended dealer net price of less than \$5.00.
  - d. Special order items.
  - e. Electrical components.
  - f. Paint, chemicals, and lubricants.
  - g. Decals and paper products.
  - h. Items purchased in kits.
7. The sender will be notified of any material received that is not acceptable.
8. Such material will be held for five working days from notification, pending instructions. If a reply is not received within five days, the material will be returned to the sender at his expense.
9. Credit on returned parts will be issued at dealer net price at time of the original purchase, less a 15% restocking charge.
10. In cases where an item is accepted, for which the original purchase document can not be determined, the price will be based on the list price that was effective twelve months prior to the RMA date.
11. Credit issued will be applied to future purchases only.

**PRICING AND REBATES**

Prices are subject to change without prior notice. Price changes are effective on a specific date and all orders received on or after that date will be billed at the revised price. Rebates for price declines and added charges for price increases will not be made for stock on hand at the time of any price change.

Multiquip reserves the right to quote and sell direct to Government agencies, and to Original Equipment Manufacturer accounts who use our products as integral parts of their own products.

**SPECIAL EXPEDITING SERVICE**

A \$35.00 surcharge will be added to the invoice for special handling including bus shipments, insured parcel post or in cases where Multiquip must personally deliver the parts to the carrier.

**LIMITATIONS OF SELLER'S LIABILITY**

Multiquip shall not be liable hereunder for damages in excess of the purchase price of the item with respect to which damages are claimed, and in no event shall Multiquip be liable for loss of profit or good will or for any other special, consequential or incidental damages.

**LIMITATION OF WARRANTIES**

No warranties, express or implied, are made in connection with the sale of parts or trade accessories nor as to any engine not manufactured by Multiquip. Such warranties made in connection with the sale of new, complete units are made exclusively by a statement of warranty packaged with such units, and Multiquip neither assumes nor authorizes any person to assume for it any other obligation or liability whatever in connection with the sale of its products. Apart from such written statement of warranty, there are no warranties, express, implied or statutory, which extend beyond the description of the products on the face hereof.

Effective: February 22, 2006



# OPERATION AND PARTS MANUAL

## HERE'S HOW TO GET HELP

PLEASE HAVE THE MODEL AND SERIAL  
NUMBER *ON-HAND* WHEN CALLING

### **UNITED STATES**

#### ***Multiquip Corporate Office***

18910 Wilmington Ave. Tel. (800) 421-1244  
Carson, CA 90746 Fax (800) 537-3927  
Contact: mq@multiquip.com

#### ***Mayco Parts***

800-306-2926 Fax: 800-672-7877  
310-537-3700 Fax: 310-637-3284

#### ***Service Department***

800-421-1244 Fax: 310-537-4259  
310-537-3700

#### ***MQ Parts Department***

800-427-1244 Fax: 800-672-7877  
310-537-3700 Fax: 310-637-3284

#### ***Warranty Department***

800-421-1244, Ext. 279 Fax: 310-537-1173  
310-537-3700, Ext. 279

#### ***Technical Assistance***

800-478-1244 Fax: 310-631-5032



### **MEXICO**

© COPYRIGHT 2008, MULTIQUIP INC.

Multiquip Inc, the MQ logo and the Essick logo are registered trademarks of Multiquip Inc. and may not be used, reproduced, or altered without written permission. All other trademarks are the property of their respective owners and used with permission.

This manual MUST accompany the equipment at all times. This manual is considered a permanent part of the equipment and should remain with the unit if resold.

The information and specifications included in this publication were in effect at the time of approval for printing. Illustrations, descriptions, references and technical data contained in this manual are for guidance only and may not be considered as binding. Multiquip Inc. reserves the right to discontinue or change specifications, design or the information published in this publication at any time without notice and without incurring any obligations.

Your Local Dealer is:



MAQUINARIA PARA CONSTRUCCIÓN S.A. DE C.V.

